

Technical Support

☎ 877-585-6223

✉ support@mace.com

Technical help is available: Monday - Friday 9am to 7pm (EST)

Documentation on all Mace Security Products can be found on our web site - <http://www.macepro.com/>



This unit requires a wireless bridge (USB or Ethernet) to communicate with the controlling PC running the Mace software.

This unit uses wireless communication. It is recommended that a Mace site surveyor is used to determine the best position for the bridge and access control units.

This unit is for Indoor use only.

Parts list

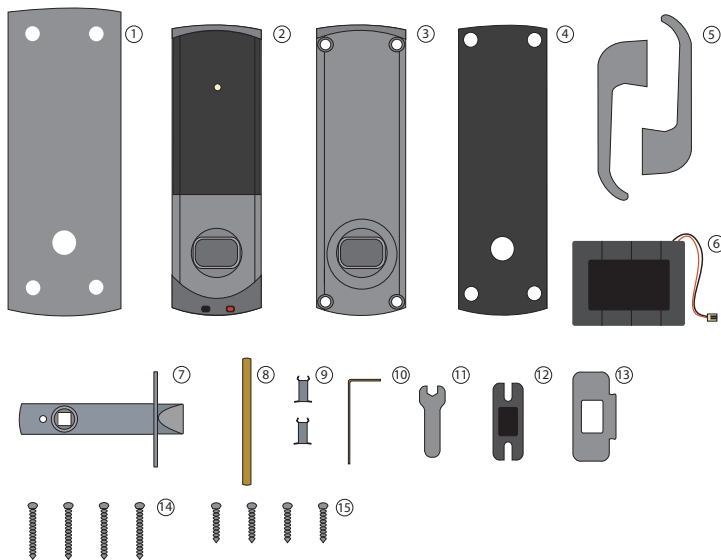

- 1) Stainless Steel Escutcheon x2
- 2) Front Lock Assembly
- 3) Rear Lock Assembly
- 4) Rubber Escutcheon x2
- 5) Left and Right Handles
- 6) Battery Pack
- 7) Tubular Mortice Lock
- 8) Square Drive Bar
- 9) 8 mm and 5/16" Sleeve
- 10) 2 mm Allen Key
- 11) 8 mm Spanner
- 12) Strike Plate Backbox
- 13) Strike Plate
- 14) Long Mounting Screws x4
- 15) Short Mounting Screws x4

Tools List

Power Drill
 Drill bits 3/8", 1"
 Philips screwdriver
 Hacksaw for cutting bolts
 Hammer / Mallet
 Chisel 1"

Stanley knife
 Adhesive tape
 Pencil
 Tape measure
 8mm spanner (supplied)
 2mm Allen key (supplied)

Installing the hardware

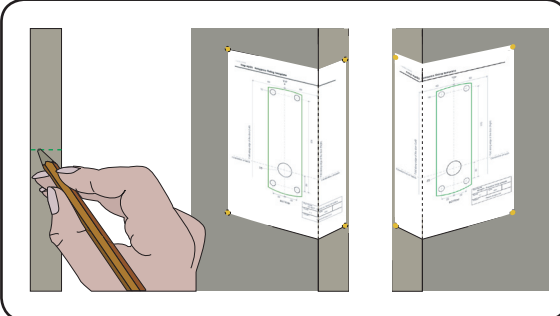

Step 1 - Marking out

Decide on the lock height and mark this on the door.

Fold the template along one dotted line and tape it to the door with the 'Centreline of Latch' at the required height. Mark the 4 x 3/8" and 1 x 1" holes. Remove the template, fold along the other dotted line and apply it to the other side of the door at the same height. Mark the holes as before.

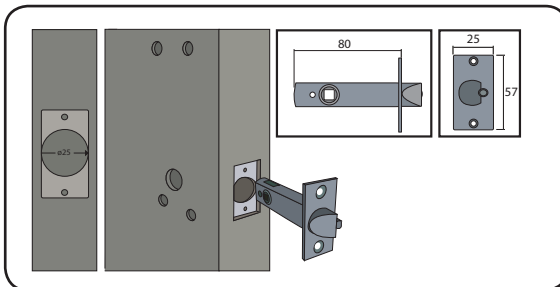

Step 2 - Drilling

Drill a 1" hole in the door edge at least 3" deep to accept the latch.

Drill the 4 x 3/8" holes for the mounting screws and a 1" hole for the square bar. To ensure accuracy you should drill these holes from both sides of the door towards the centre. This also avoids the risk of damaging the door face when the drill breaks through.

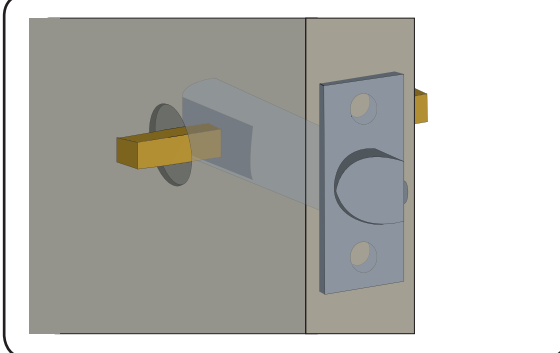

Step 3 - Fitting the latch

Slide in the latch and draw around the faceplate. Remove the latch and score the outline with a Stanley knife to avoid splitting the wood when chiselling.

Chisel a rebate allowing a flush fit for the latch. Re-fit the latch with the plunger facing away from the door frame and secure with two latch screws.

Cut the square bar to length (Door thickness + 3/4") and slide into the latch.

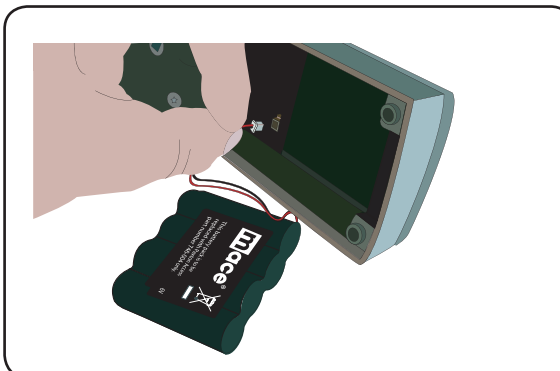

Step 4 - Fitting the battery pack

Remove the access plate at the rear of the unit by removing the top standoff screws. Push the battery pack lead onto the white power plug.

Fit the battery pack into the unit and replace and secure the access plate.

NOTE: The unit is now active and is LOCKED with the handle disconnected.

Where possible, the unit should now be enrolled BEFORE mounting it on the door.

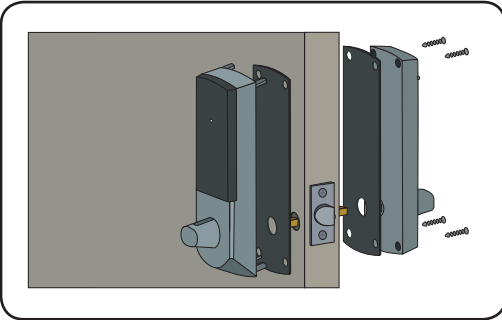

Step 5 - Mounting on the door

Select the short (doors thinner than 1 3/4") or long mounting screws and cut to length if required. (door thickness + 3/16")

The kit includes optional stainless steel escutcheons that may be fitted to cover the effects of a previous installation.

Fit the rubber escutcheons to the front and back plates. Present the front and rear lock assembly to the door, locating the square drive in its recess and join the two parts together with 4 mounting screws.

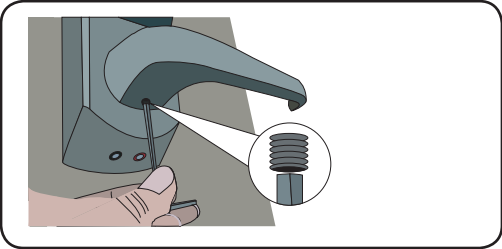

Step 6 - Fitting the handles

Fit the two handles, positioning the screw holes to the underside and secure with the grub screws provided.

Check the operation of the lock - See Commissioning checks.

Step 7 - Marking out the strike plate

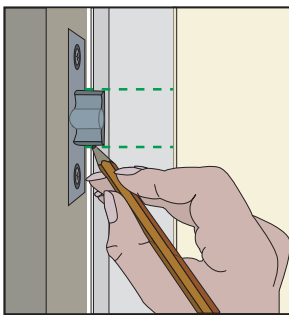

Fig A

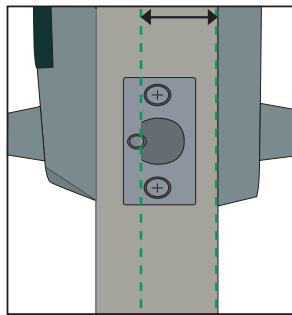

Fig B

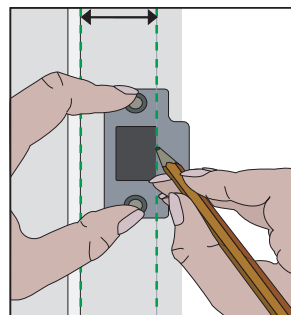

Fig C

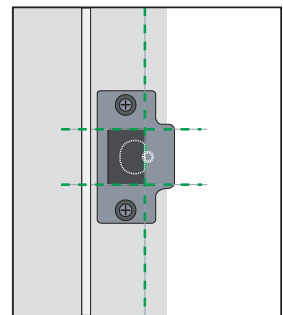

Fig D

Fig A - Vertical position of the strike plate - Close the door and mark the top and bottom position of the latch horizontally across the frame.

Fig B - Horizontal position of the strike plate - Measure the distance from the back edge of the door to the flat face of the latch. (NOT the plunger.)

Fig C - Mark this distance on the frame to show how far back the plate needs to be to hold the door closed.

Fig D - Position the strike plate within these guide lines. Mark the positions of the fixing screws and draw around the 'cut-out' in the strike plate.

Step 8 - Fitting the strike plate

Chisel out a 5/8" aperture to receive the latch bolt.

Fix the strike plate with one latch screw to the surface of the frame.

FROM THE INSIDE: Gently close the door and check that the latch enters the aperture easily with no additional 'play' in the frame. Slight adjustment can be made by moving the plate slightly. When satisfied, draw around the outline of the strike plate, remove it. Score around the outline and then cut the rebate to enable the strike plate to lie flush with the surface.

Fix the strike plate using two latch screws and check the lock operation. Remove the strike plate and increase the aperture to accept the strike plate backbox. Now re-fix the strike plate and check the operation of the 'anti-shim' plunger and the door.

The unit is now fully operational and should be enrolled as soon as possible to preserve battery life.

Software installation

Once all the ACUs have been tested and the units powered up, the bridges need to be configured.

A USB bridge will be registered by the Mace software automatically. This displays in the Mace Server Configuration Utility/bridge as a fixed IP entry.

To register an Ethernet bridge, click on Detect and setup the IP addresses as required. See also: [Ins-30085-MS Mace Security wireless bridge TCP/IP](#).

The current specification for compatible PC hardware, network and operating systems is available on our website.

Enrolling a MaceTrac wireless

The unit must first bind to a wireless bridge before it will enroll itself onto the system. The term 'bind' is used to denote the fixed relationship between a unit and its bridge.

1. Create a user record in the database and assign a token to the user. This record can be deleted after the installation is complete.
2. You must now wake up the unit by moving the handle.
3. Present the same user token to the unit which will then transmit the token number and wait for a response from a bridge.

The software has the 'Enable commissioning mode' set as a default. If this has been turned off in the Server configuration utility, it must be enabled for this process to succeed.

If more than one bridge replies, the unit checks the signal strength and selects the strongest bridge to communicate with. The Mace software confirms that the token number is in the database and if so registers this MaceTrac/bridge as a permanent binding.

An entry is then made on the Doors screen and a special icon is used to denote the wireless connection. 

The Blue LED will now flash for several minutes while its software is updated to match the current PC version.

There is NO detection function. It is recognised that there could be security issues if the wireless units were detectable from outside the site. During installation, a unit makes a permanent link with a wireless bridge which will then only talk to registered units. The Server configuration utility also has an 'Enable commissioning' mode which can be turned off to inhibit units being added.

Commissioning checks

With the product fixed securely to the door:

- 1) Extend the door open time by changing this door's settings on the Mace PC. Set 'Door open time' to 20 seconds and then present a user card at the door. Before each check, present a user card to unlock the door.
- 2) Check that the handles are running smoothly, this is best done by depressing the handle all the way to the bottom and then releasing it as slowly as possible, if the handle is left behind at any point it is likely that the product has not been installed squarely enough. Check the handle on both sides of the door.
- 3) If your finger is able to leave the handle, remove the unit from the door (or slacken the four fixing screws) and see if the problem goes away. If it does, then the installation onto the door is at fault and the drilling of the mounting holes should be checked for alignment.
- 4) Once the install has successfully passed this test return the door to normal operation by changing the PC setting for this door back to its previous door open time (default 3 seconds) and present a user card.

This test confirms the correct and free operation of the mechanical lock and also ensures that the electronic circuits will shut down correctly preserving battery life.

Software configuration

Door name: Name the ACU.
Door open time: Set the door open time.
Unlock the Door during: Permanently unlocks the door while this time zone is active. - Should be set to 'At No Time' for normal user operation.

Reader: Local settings for the reader.
Output: Configures the lock for timed release or toggle mode.
Events: Shows the events for this control unit only.
Access Rights: Lists users who have access through this door.

Name: Each reader can be named individually if required.
Reader operating mode: Set the operating mode.
Timed operating modes: A different operating mode can be configured within a time window.

Normal Operation - LED Indications

Wireless activity is signalled by a Blue LED. This will flash each time the unit communicates with the Mace software.

Presenting a valid user card to the unit will cause the LED to flash Green briefly and the handle will then engage. The unit will beep during this time to advise the user that access has been permitted.

The external handle is only engaged once access has been granted. The inside handle is always engaged.

A button on the inside allows the internal handle to be held in the unlocked position.

LED indications

Blue	Indicates wireless communication with the Mace software
Green flash + beep	A valid user card has been presented and the handle is engaged
Red flash + low beep	An invalid user card has been presented - No access granted
Red flash 3 times	Activity has been sensed but no user card has been presented
Amber constant flashing	A valid user card has been presented - the handle is not horizontal and so the latch cannot release
Red constant flashing	The handle is being held down - The latch cannot relock

Mace Security wireless communication

The access control unit connects to the Mace software running on the PC using proprietary wireless technology. A wireless bridge enables communication between Mace software and the whole Mace wireless family of access control products.

Radio signals do not always behave as you might expect. For example, a cell phone that displays a full signal on one part of the site will lose signal completely only a few feet away. These problems can be addressed by using the site surveyor kit.

See also: [AN1095-MS](#) [Wireless operation - How does it work?](#)
[AN1096-MS](#) [How to plan a wireless installation.](#)
[Ins-30096-MS](#) [Mace Security site surveyor.](#)

Radio frequency

The unit is set to channel 11 (2.405 GHz) as this frequency is normally clear of other device transmissions. Technical Support can advise if you are concerned about interference from adjacent radio based (WiFi) equipment.

MaceTrac wireless / server operation

This standalone unit stays in a sleep mode while there is no activity. The Mace server cannot wake up the unit. If the handle is moved, it powers up the reader circuits in readiness for a token read. Should nothing occur within 3 seconds, the unit will go back to sleep.

If a token is read, then the unit moves into full operation. The token number is checked against the stored database and access is granted or denied as per a standard access control unit.

The unit now sends this data via its wireless bridge connection to the Mace server software and the blue LED will flash to indicate this activity. If any updates need to be sent to the unit, including changes to the user data, these are now transmitted back. The unit will then go back to sleep again waiting for further activity.

After 1 hour of inactivity, the unit will send a heartbeat to the PC which responds with any updates, as above. This keeps the units updated even when there is no activity at the door. The 1 hour delay is mitigated by the vastly increased battery life in each unit and the fact that any user activity (card read or handle use) will also cause an immediate update to be made. It therefore follows that a new user may need to trigger an update before being given access through a door.

Some of the software features (e.g. Fire alarm integration, Anti-passback) are not available on wireless products as this communication method is not suitable for data critical applications.

During the 1 hour sleep period, any changes at the PC will not be received. If an immediate card update is required, the unit must be woken up by briefly depressing the handle to initiate a data transfer.

To preserve battery life, a door held unlocked by a timezone will ignore the wakeup function. It will check for updates, reducing in frequency from 1 minute to 1 hour while the door remains unlocked.

MaceTrac wireless reset

The unit holds the address information for the bridge that it has bound with. It will therefore never communicate with any other bridge. This can cause problems if the unit is to be used in another location.

The unit requires a hardware reset to clear its bridge information. This is achieved as follows:

1. Remove the unit from the door by removing the 4 mounting screws on the rear lock assembly.
2. Remove the access plate at the rear of the front lock assembly (top two standoff screws).
3. Locate the reset push button at the lower right corner of the circuit board.
4. Hold the button down and wake up the unit by briefly depressing the handle. The unit will give a single beep.
5. Push the reset button 4 more times and the unit will beep 5 times and display an AMBER LED.
6. Replace the access plate.
7. Enrol the unit - as above.
8. Refit the lock to the door with the 4 mounting screws.

Low battery warning

When the battery voltage falls below 4V, the user will see a delay between the card being read and access being granted. This delay provides a warning that the battery pack should be replaced.

The warning delay starts at 5 seconds, increasing up to 25 seconds as the battery discharges with use.

Battery replacement

1. Remove the unit from the door by removing the 4 securing screws on the rear lock assembly.
2. Remove the top two standoff screws - Fig 1.
3. Remove the access plate to reveal the battery pack. - Fig 2.
4. Unplug the lead and replace the pack with a new battery pack. - Fig 3.
- (The unit will retain its settings and should not be manually reset).
5. Refit the access plate and secure.
6. Refit the unit to the door.

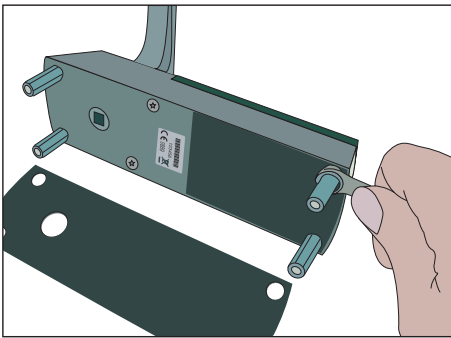

Fig 1

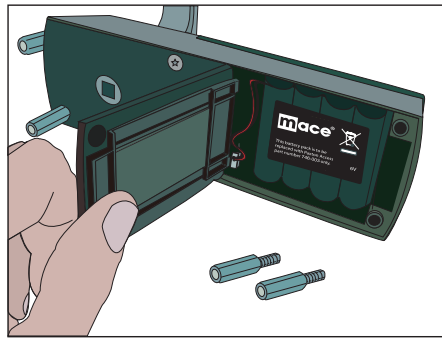

Fig 2

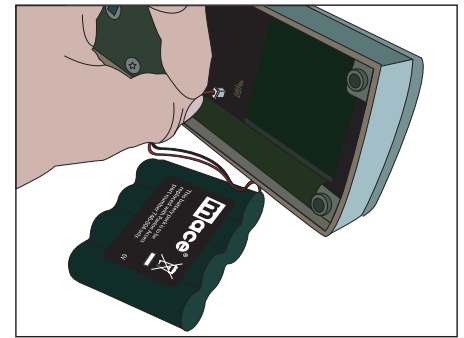
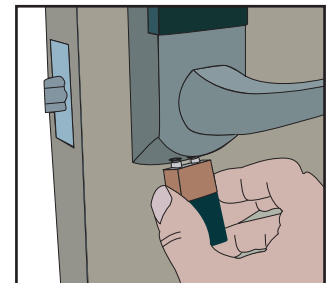

Fig 3

Recovery from a flat battery

Should the battery pack become discharged, the unit will no longer function - this could be in the locked or unlocked state. The application of an external PP3 9V battery will allow the circuitry to operate as normal.

This allows the door to be opened with a valid user card giving access to the lock allowing the battery pack to be replaced.



-ve +ve

Alarm sounder

The alarm is activated when the door fails to re-lock itself. The alarm will sound for 60 seconds during which time the unit will try to lock the door once every 10 seconds. After 60 seconds the unit will then shut down. When the unit is woken up, it will immediately try to lock the door. If it fails, the alarm cycle will start again. Failure to relock will substantially reduce battery life.

Specifications			
Features	Min	Max	
Number of Cards		10,000	
Access Levels		250	
Time Zones		64	
Maximum door open time	1 sec	99,999 sec	
ACU's per bridge - Recommended		10	
Bridge (data lines) per system		100	
Wireless range to ACU		20 yds	Use site surveyor
Events stored in ACU with no server connection		4,096	
Read Range	Token	Keyfob	
	2 inch	1 inch	
Environment	Min	Max	
Operating temperature - Battery limits	0 °C (-32 °F)	+55 °C (+131 °F)	
Waterproof			No
Vandal resistance			Low
Battery type - High capacity (746-003)			Battery Pack
Typical Battery Life		30,000 operations	
Dimensions	Width	Height	Depth
Reader/Keypad module (required space on door)	2 3/8 inch	7 5/8 inch	1 inch
Total outside dimensions (includes handle clearance)	6 inch	7 5/8 inch	2 7/8 inch

FCC Compliance

This device complies with Part 15 of the FCC Rules. Operation is subject to the following two conditions: (1) this device may not cause harmful interference, and (2) this device must accept any interference received, including interference that may cause undesired operation. Changes or modifications not expressly approved by the party responsible for compliance could void the user's authority to operate the equipment.

This product is not suitable for retail sale. All warranties are invalid if this product is not installed by a competent person.